

# DNX De-NOx module, design example

## Embedded type

Local Scrubber Cabinet door panel      Local Scrubber Cabinet

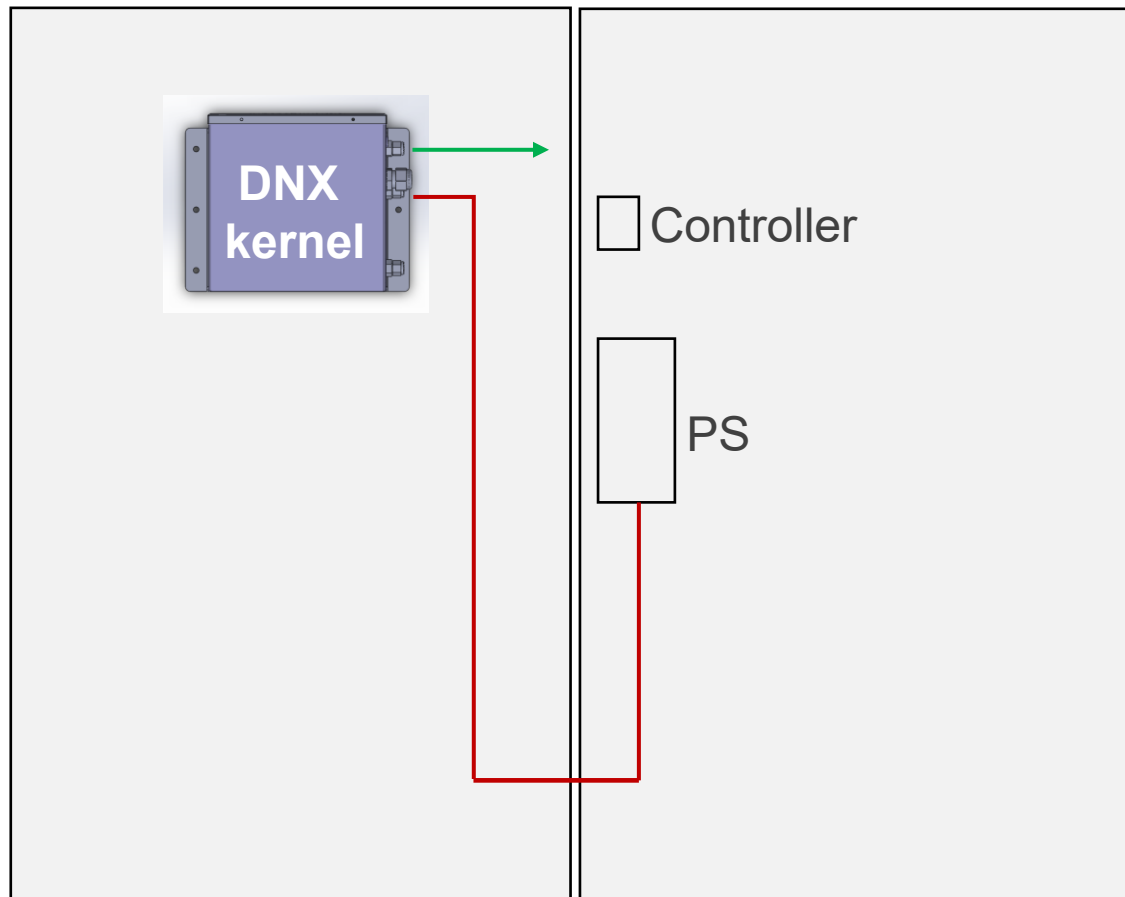

## External type

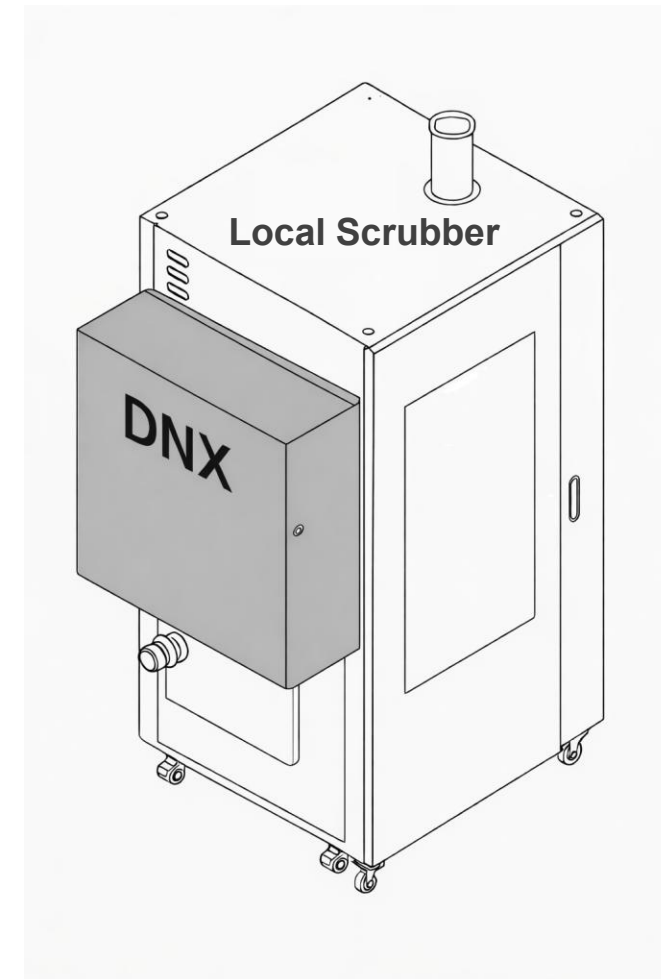

# DNX product features

---

- **Compact modular design:** flexible installation on door panel, inside cabinet, or as an external add-on to LSC systems.
- **Proven NO<sub>x</sub> reduction:** 400 ppm → <10 ppm (or N.D.)
- **Integrated DHC:** Eliminate hydrogen leakage to enhance safety
- **Semi S2 and Explosion-proof certification**